

CB359 ADHESIVE MSDS

INSTRUCTION SHEET

CB904 ABRASIVE PAD (QTY 10)

CB106 MIXING TIPS (QTY 10)

CB911 SOLVENT WIPES (QTY 10)

CB359-50 ADHESIVE CARTRIDGE, 50 ml (QTY 2)

CB100-21 ADHESIVE DISPENSER WITH SLIDE (QTY 1)

CN614CR06P NUTPLATES (QTY 100)

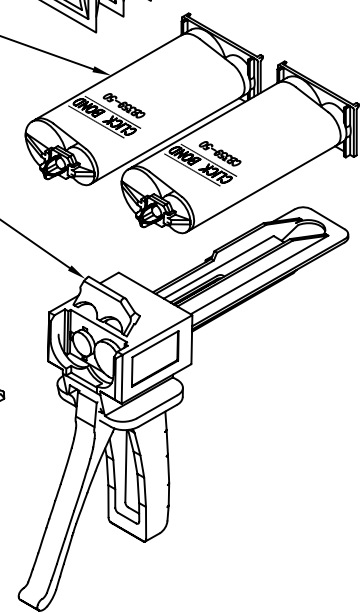
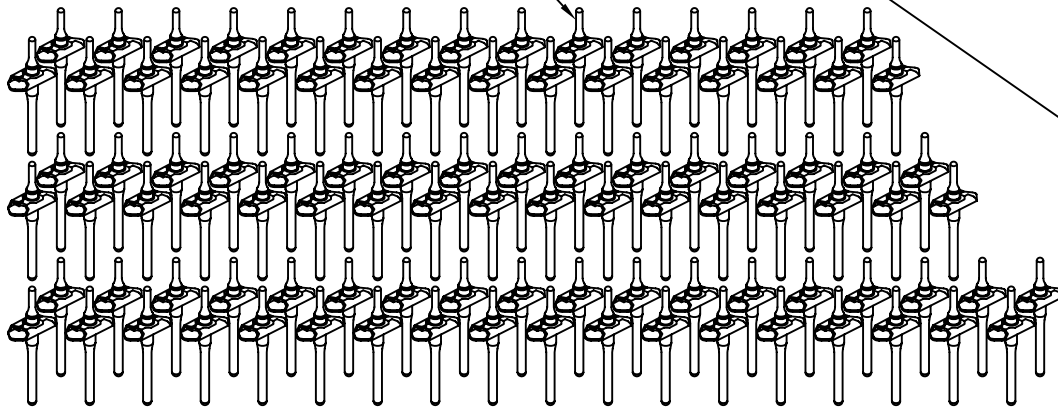

PART NUMBER

KA 100 E2 CN614CR06P

FASTENER PART NUMBER
ADHESIVE TYPE - CB359-50 ACRYLIC ADHESIVE CARTRIDGE (2)
NUMBER OF FASTENERS IN KIT - 100
KIT, POLY BAG, WITH SOLVENT WIPES AND ABRASIVE PADS

UNLESS OTHERWISE SPECIFIED, ALL DIMENSIONS ARE IN INCHES AND TOLERANCES ARE AS SHOWN BELOW. DIMENSIONAL TOLERANCES AND SYMBOLS PER ANSI Y14.5M-1982.

PROPRIETARY PARTS SHOWN IN THIS DRAWING ARE THE SUBJECT OF ISSUED UNITED STATES AND FOREIGN PATENTS AND PATENTS PENDING. UNAUTHORIZED REPRODUCTION AND/OR DISTRIBUTION OF THIS DRAWING IS SPECIFICALLY PROHIBITED.

CLICK BOND

CARSON CITY
NEVADA 89706

APPROVALS	DATE
DRAWN <i>BPEREZ</i>	6NOV08
CHECKED <i>JAC</i>	6NOV08
RELEASED <i>CGH</i>	6NOV08
REVISED	

TITLE			
KIT, EPOXY ADHESIVE, SPECIAL			
SIZE	CAGE CODE	DWG. NO.	REV.
A	66530	KA100E2CN614CR06P	0
SCALE	1/2	6NOV08	SHEET 1 OF 1